

SPECIFICATIONS

- Solid and stable 3" round 11-gauge tubular steel with a combination of 2x3" oval tubing and 2" round tubing.
- Powder coat finish – Platinum Sparkle and Cathedral Gray.
- USA-Made 1/8" military-spec nylon coated aircraft cable.
- Durable high density pads upholstered in premium grade naugahyde.
- User friendly "free-flow" handle design.
- Full length protective steel weight shields.
- Includes exercise placard and DVD showing the recommended basic exercises.
- (2) 200 lbs. solid steel weight stacks with high visibility weight labels.

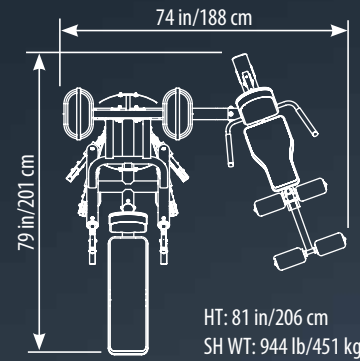

LIGHT COMMERCIAL WARRANTY:

Warranty* applies only to facilities where the HTX-2000 would be used by no more than 20 people per day.

10 YEARS: Structural main frames, welds, cams and weight plates.

5 YEARS: Pivot bearings, pulleys, bushings and guide rods.

1 YEAR: Linear bearings, pull-pin components, and all other parts not mentioned.

6 MONTHS: Upholstery, cables, finish and rubber grips.

*Refer to the Owner's Manual for details.



TUFFSTUFF FITNESS EQUIPMENT INC.
13971 Norton Avenue, Chino, CA 91710
PH: 909-629-1600 FX: 909-629-4967

www.tuffstufffitness.com

TUFFSTUFF
FITNESS

HTX-2000

DUAL-STACK FUNCTIONAL TRAINER





HTX-2000

DUAL-STACK FUNCTIONAL TRAINER

The TuffStuff HTX-2000 is the ideal choice for those facilities searching for a compact, easy-to-use, strength training platform for their clients and guests. European inspired styling combined with a space saving, forward facing design featuring six individual pulleys that swivel 360°, provides virtually unlimited functional and traditional strength training options. Plus the exclusive leg extension/curl station offers exercises not commonly found with other functional trainers.

- IDEAL FOR:**
- Hotels & Motels
 - Corporate Wellness
 - Community Centers
 - Private Studios
 - Home Fitness Rooms
 - Apartments & Condominiums
 - Fire & Police Departments
 - Medical & Rehabilitation Centers
 - Personal Training Facilities

OVER 42 EXERCISES

