

TUFFSTUFF

AMERICA'S PREMIER EXERCISE EQUIPMENT



SP-4407 CABLE COLUMN ASSEMBLY MANUAL REV. 0

Simplex PLATINUM

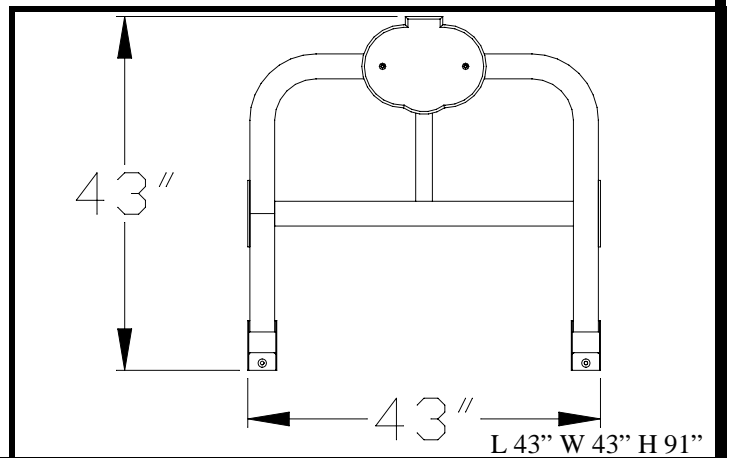

Introduction

About the Cable Column SP-4407

Congratulations on your new purchase of the **Cable Column**. We hope you are completely satisfied with this product and wish you many years of enjoyment.

Tuff Stuff Equipment

This Tuffstuff product has been built to precise quality standards and has been carefully packaged to ensure that damage will not occur during shipment. The Tuffstuff Warranty and signature indicating final inspection has been conducted by our line foreman, is an expression of our confidence in the completeness, the materials, and workmanship of this product.

Warranty

SEE A COPY OF WARRANTY ON BACK PAGE

Registration Card

To avoid unnecessary delays in warranty service and to insure that a permanent record of your purchase is on file with our factory, be sure to complete the warranty registration card and send it to:

TUFFSTUFF Fitness Equipment Inc., today.

Specifications

1. Maximum Wt. Capacity - 150 Lbs.
2. Total Machine Weight - 455 Lbs.
3. Footprint (LWH) - See Front Page

Note: Due to continuing product improvements, specifications and designs are subject to change without notice.

Safety First

Regardless of how enthusiastic you may be about getting on your equipment and exercising, take the time to ensure that your safety is not jeopardized. A moment's lack of attention can result in an accident, as can failure to observe certain safety precautions.

1. Read, study and understand the Owner's Manual and all the warning labels on this product. Furthermore, it is recommended to familiarize yourself and others with the proper operation and workout recommendations for this Tuff Stuff product prior to use. Some of this information can be obtained in this Owner's Manual, as-well-as from your local Tuff Stuff retailer.
2. It is imperative that you retain this Owner's Manual and be sure all warning labels are legible and intact. Replacement of Owner's Manuals and labels are available from your local Tuff Stuff retailer.
3. Consult with your physician before beginning any exercise program.

Prior to the Assembly of the Cable Column

1. We advise you to consult your local TuffStuff retailer if you should have a question or problem regarding the proper assembly of this unit.

Tool Requirements

1. One 3/4" combination wrench
2. One 9/16" combination wrench
3. One 7/16" combination wrench
4. One ratchet
5. One 3/4" socket
6. One 9/16" socket
7. One 7/16" socket
8. Rubber mallet
9. Windex or household glass cleaner
10. One can silicone spray / teflon spray lubricant
11. Measuring tape
12. Utility knife

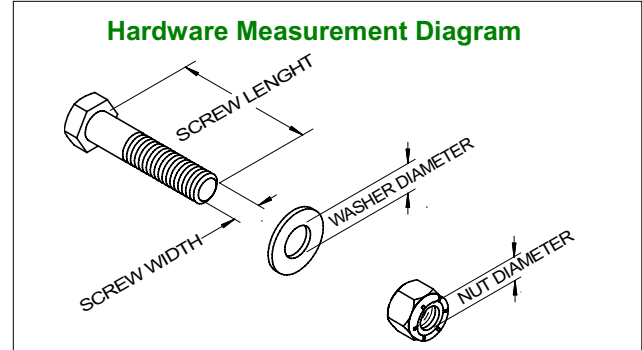

Safety Precautions

4. Use proper discretion when children are present.
5. Frayed or worn cables can be dangerous and may cause injury. Periodically check these cables for any indication of wear.
6. Keep hands, limbs, loose clothing and long hair well out of the way of moving parts.
7. Do not attempt to lift more weight than you can control safely.
8. Inspect the Unit for any sign of wear on parts, hardware becoming loose or cracks on welds. If a problem is found, **do not use or allow the machine to be used** until the defective part is repaired or replaced.

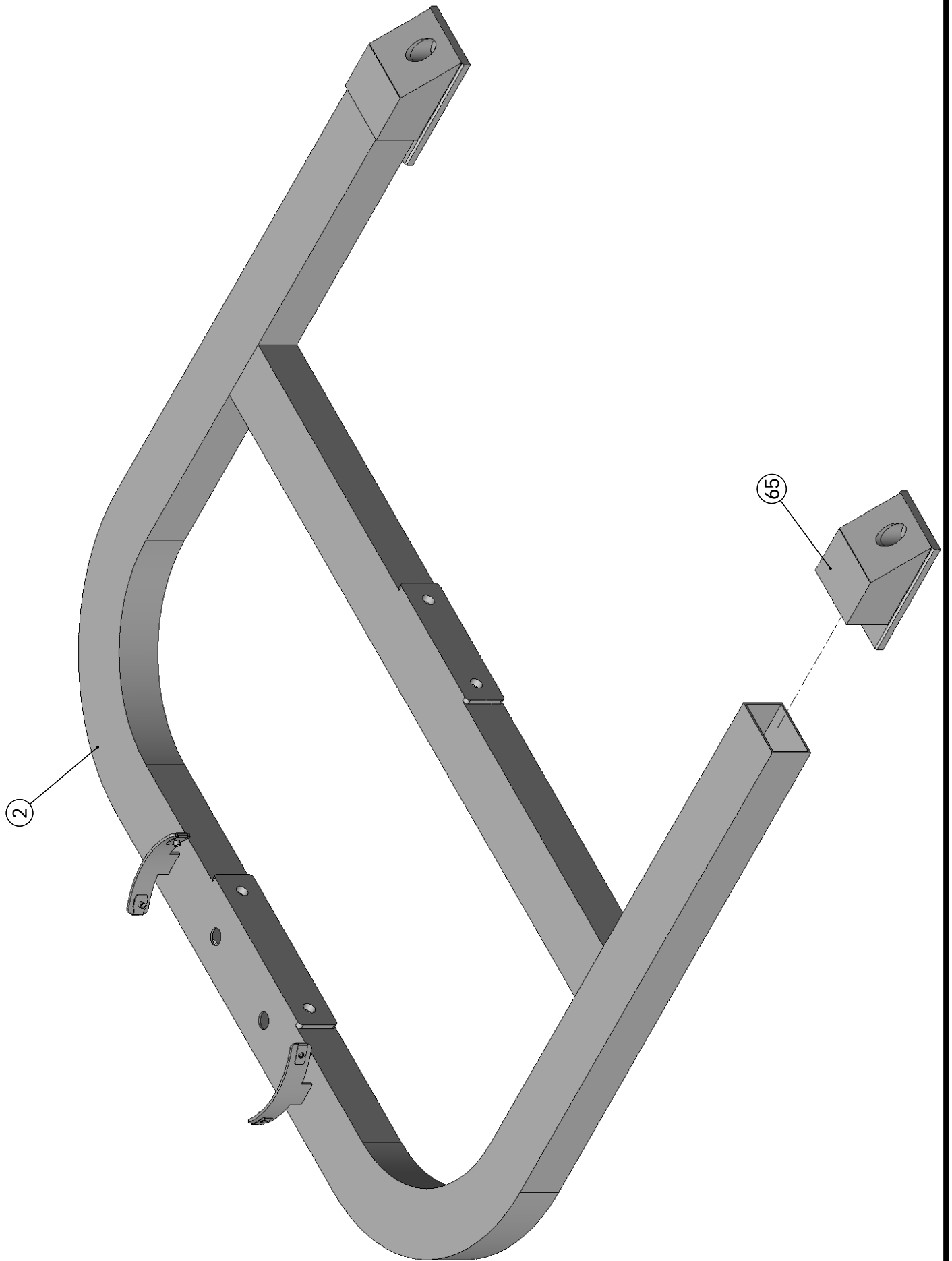

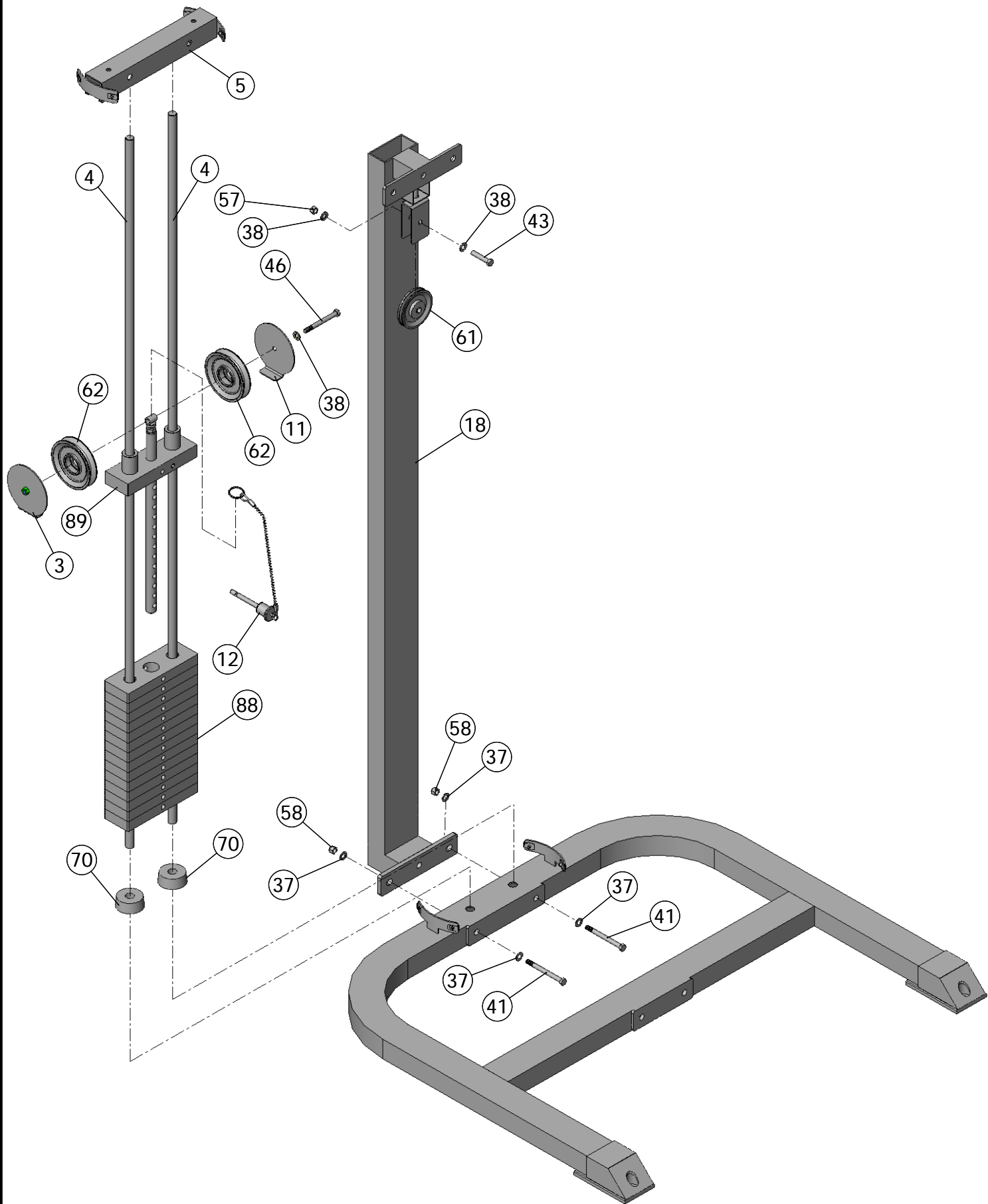

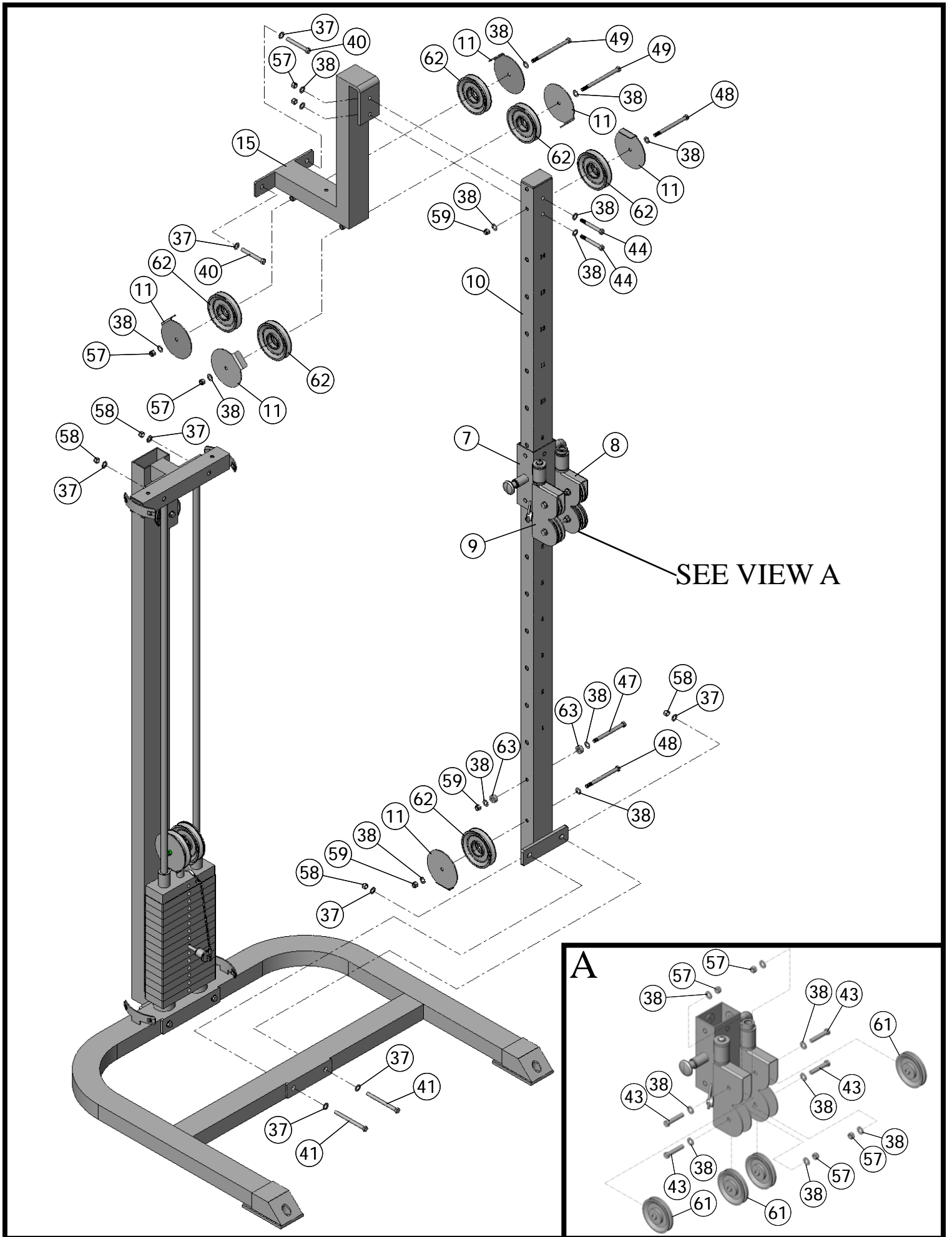

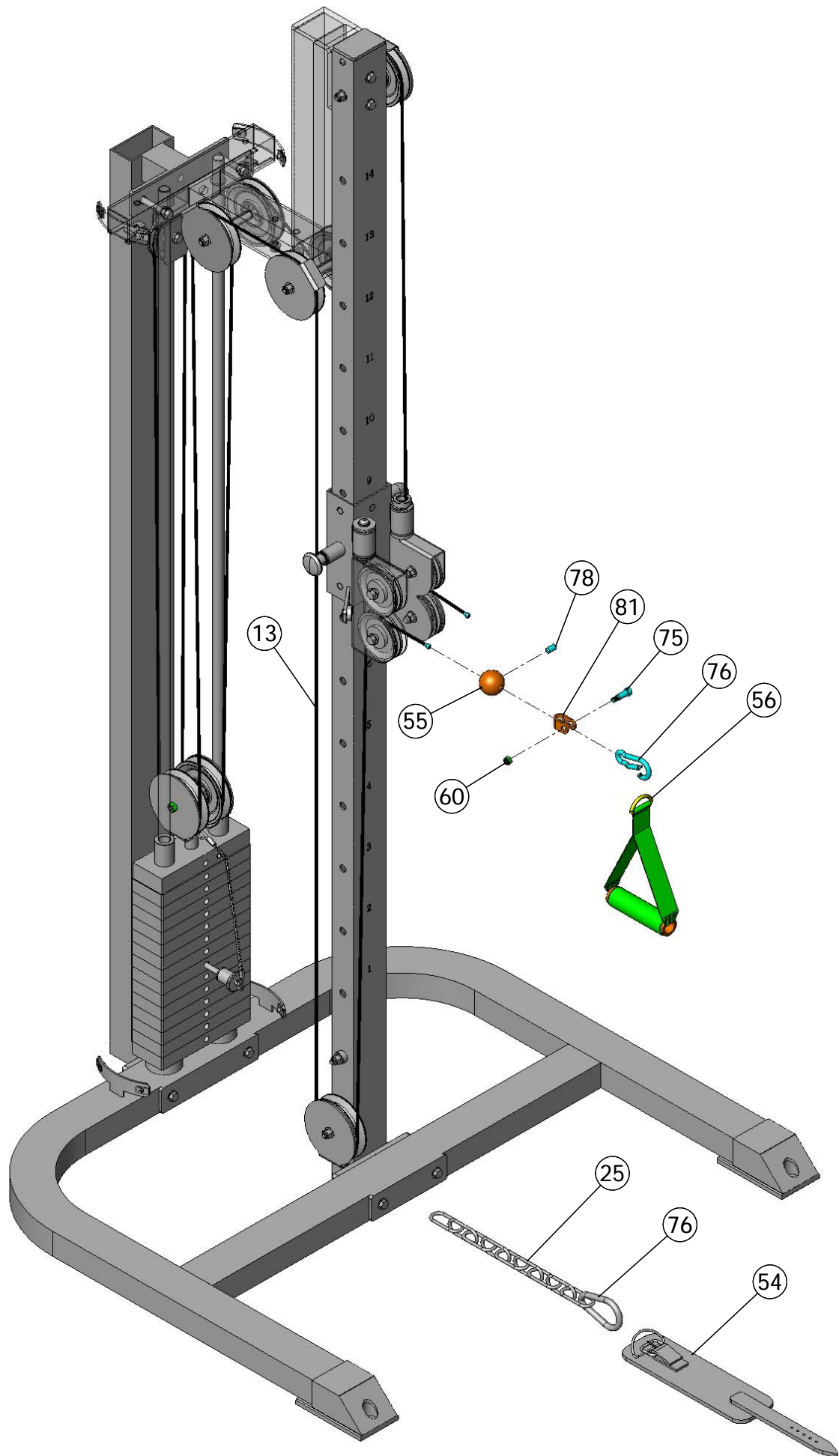

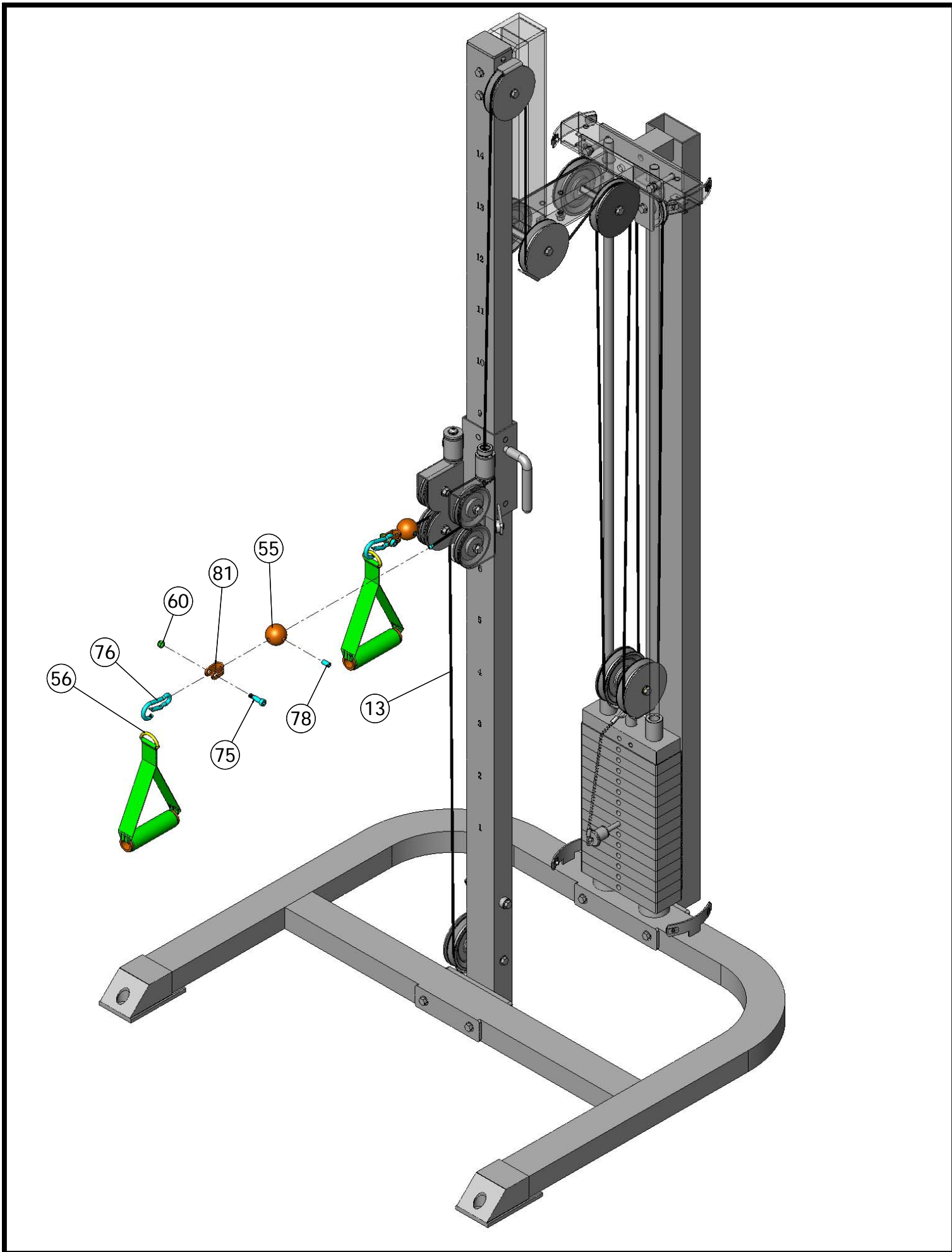

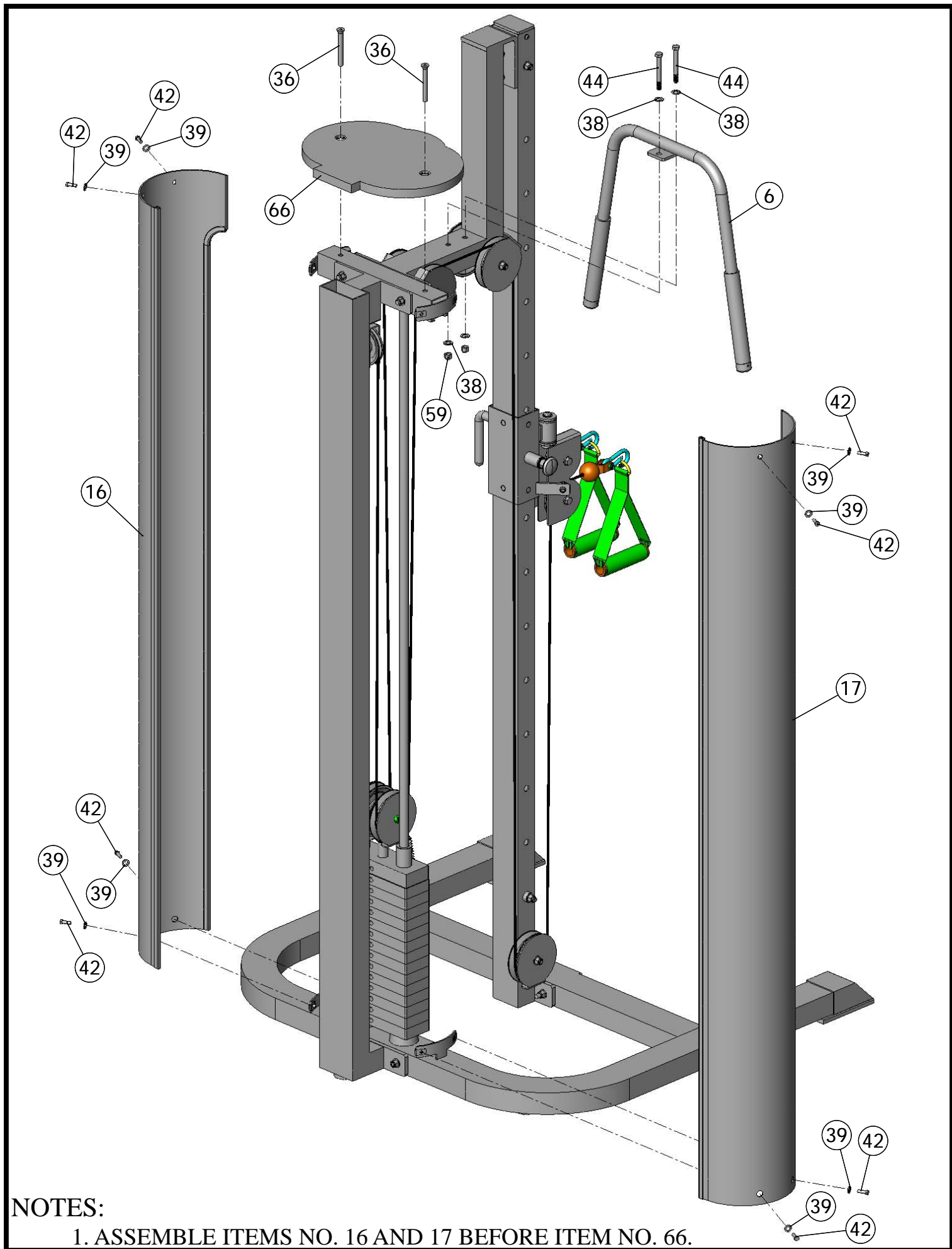

COLOR CHART
 GRAY= SUB-ASSEMBLY PARTS
 BLACK= HARDWARE

SP-4407 Single Column Parts List

Item No.	Description	Part No.	Qty.	Item No.	Description	Part No.	Qty.
1	ADJUSTABLE PULLEY BRACKET	UP0127	1	46	HEX HEAD CAP SCREW GR-5 B/O 3/8-16 X 3 3/4	BNH0281	1
2	BASE FRAME	UP5107	1	47	HEX HEAD CAP SCREW GR-5 B/O 3/8-16 X 4 1/2	BNH0284	1
3	4 1/2 PULLEY COVER WITH NUT	UP3675	1	48	HEX HEAD CAP SCREW GR-5 B/O 3/8-16 X 4 3/4	BNH0318	2
4	GUIDE ROD 3/4 X 72 1/2	UP5111	2	49	HEX HEAD CAP SCREW GR-5 B/O 3/8-16 X 6	BNH1735	2
5	GUIDE ROD RETAINER	UP5068	1	50	HEX KEY 3/16"	BNH0371	1
6	HANDLES	UP5116	1	51	HEX KEY 3/32"	BNH0372	1
7	HIGH/LOW CARRIAGE	UP5115	1	52	HEX KEY 5/32"	BNH0373	1
8	HIGH/LOW DOUBLE PULLEY BKT (HOLLOW SHANK)	UP1023	1	53	HEX KEY 7/32"	BNH0575	1
9	HIGH/LOW DOUBLE PULLEY BKT (SOLID SHANK)	UP1022	1	54	LEATHER ANKLE STRAP	BNH1231	1
10	HIGH/LOW SELECTORIZED UPRIGHT	UP5113	1	55	NYLON BALL W/THREADED SOCKET 1 3/4 X 5/16	BNH0022	2
11	PULLEY COVER (ROUND)	UP5011	7	56	NYLON D HANDLE	BNH1215	2
12	SELECTOR PIN W/COIL 3/8 X 3 1/4 GOLD KNOB	UP3051	1	57	NYLON INSERT JAM LOCK NUT B/O 3/8-16	BNH0365	9
13	SINGLE COLUMN CABLE	UP5114	1	58	NYLON INSERT LOCK NUT B/O 1/2-13	BNH0212	6
14	TOP PLATE DOUBLE PULLEY BRACKET	UP0996	1	59	NYLON INSERT LOCK NUT B/O 3/8-16	BNH0214	5
15	TOP UPRIGHT CONNECTOR	UP5112	1	60	NYLON INSERT LOCK NUT B/O 5/16-18	BNH0215	2
16	WEIGHT SHROUD 70 1/4" LT	UP5110	1	61	NYLON PULLEY 3/8 X 1 X 3 1/2 BLACK	BNH0553	5
17	WEIGHT SHROUD 70 1/4" RT	UP5109	1	62	NYLON PULLEY 3/8 X 1 X 4 1/2 BLACK	BNH0506	8
18	WEIGHT STACK FRAME 72 1/2"	UP5108	1	63	NYLON SPACER 3/8 X 3/4 X 3/8	BNH0392	2
19	ALUMINUM CAP 1" RD. (CAP-100)	BNH0537	2	64	NYLON STEM BUTTON 12.5 mm X 26 mm x 9.5 mm	BNH0547	8
20	CHROME WASHER 3/8 X 1 1/2	BNH1015	1	65	PLASTIC END CAP 2 X 3 (SIMPLEX LINE)	BNH0606	2
21	BRONZE BUSHING 1 X 1 1/4 X 3/4 X 1 1/2 X 1/8	BNH0527	4	66	PLASTIC SHROUD LID 5/8 X 14 1/8 X 10	BNH0185	1
22	BUTTON HEAD SOCKET CAP SCREW B/O 1/4-20 X 3/8	BNH1346	2	67	PLASTIC TUBE END 0.9785 X 1.1655 X 0.4225	BNH1824	1
23	BUTTON HEAD SOCKET CAP SCREW B/O 3/8-16 X 1	BNH0115	1	68	PULL PIN 1/2 X 2 7/8 LIGHT SPRING (YELLOW KNOB)	BNH0641	1
24	CHROME INSERT CAP 2 X 3	BNH1503	1	69	RETAINING SNAP RING EXT. PLAIN .925 X 1 X .042	BNH0419	1
25	COIL CHAIN Z/P 3/16 X 8	BNH1214	1	70	RUBBER DONUT 3/4 X 2 1/2	BNH0068	2
26	DECAL-ADJUST CABLE HERE	BNH0789	1	71	RUBBER GRIP 1 ID X .125 X 7 1/4	BNH0963	2
27	DECAL-CAUTION 1 3/4 X 5-1/2 HORIZONTAL	BNH0126	1	72	RUBBER GRIP 1/2 X 4	BNH0530	1
28	DECAL-DANGER TIGHTEN THIS RET...., 3/4 X 1-1/2	BNH0142	1	73	RUBBER GROMMET 3/4" ID (2867-012)	BNH0401	2
29	DECAL-EXERCISE SP-4407 SINGLE COLUMN 5 1/4 X 18.267	BNH1687	1	75	SHOULDER BOLT ALLOY 3/8 X 3/4	BNH0718	2
30	DECAL-FOR BEST PERFORMANCE 1-1/4 X 1-1/2	BNH0143	1	76	SNAP LINK Z/P 8MM X 80MM	BNH0065	3
31	DECAL-WARNING KEEP HANDS AND FINGERS...	BNH0620	1	77	SOCKET SET SCREW ALLOY 10-32 X 1/8	BNH0473	4
32	DECAL-WEIGHT NUMBERS REF TP-15 (150 lbs)	BNH1544	1	78	SOCKET SET SCREW ALLOY 3/8-16 X 3/4	BNH0476	2
33	EDGE PROTECTOR CHROME 11 GA	BNH1724	4	79	SPLIT LOCK WASHER B/O 1/2"	BNH0653	2
34	FINISHED HEX NUT B/O 1/2-13	BNH0201	1	80	SPLIT LOCK WASHER B/O 3/8"	BNH0658	1
35	FINISHED HEX NUT B/O 1/2-13	BNH0201	2	81	STRAP BRACKET 20 #SF20 STAINLESS STEEL	BNH0562	2
36	FLAT HEAD SOCKET CAP SCREW B/O 3/8-16 X 3	BNH0787	2	82	SUPER LUBE TEFLON LUBRICANT 82340	BNH0704	2
37	FLAT WASHER SAE B/O 1/2"	BNH0238	14	83	TUFFSTUFF LOGO ALUMINUM SMALL	BNH1323	1
38	FLAT WASHER SAE B/O 3/8"	BNH0239	31	84	URETHANE BUMPER 1 3/4	BNH0229	7
39	FLAT WASHER USS B/O 1/4"	BNH0233	8	85	URETHANE BUMPER 962	BNH0244	2
40	HEX HEAD CAP SCREW GR-5 B/O 1/2-13 X 3 5/8	BNH1842	2	86	U-STYLE TAPPED HOLE NUT 1/4-20	BNH0708	8
41	HEX HEAD CAP SCREW GR-5 B/O 1/2-13 X 4 5/8	BNH1843	4	87	U-STYLE TAPPED HOLE NUT 3/8-16	BNH1211	2
42	HEX HEAD CAP SCREW GR-5 B/O 1/4-20 X 3/4	BNH0890	8	88	10 LB CAST WEIGHT PLATE GREY	BNH0904	14
43	HEX HEAD CAP SCREW GR-5 B/O 3/8-16 X 1 3/4	BNH0274	5	89	10 LB TOP PLATE SELECTOR BAR 14 WTS 16.5 LONG	BNH1174	1
44	HEX HEAD CAP SCREW GR-5 B/O 3/8-16 X 3	BNH0282	4				



TuffStuff Basic Strength Equipment Safety and General Maintenance

All TUFFSTUFF strength equipment is designed and manufactured to offer maximum, long-life service with minimal maintenance. However, safety inspection and routine maintenance in your facility should be the utmost importance in your daily operation. Information presented in these pages will serve as a basic guideline to design your own inspection procedures.

Part One: General Inspection and Cleaning

Equipment should be wiped down with a damp cloth and dried on a daily basis. The powder coat finish should be polished with a good car wax on a monthly basis. A daily wipe down of the upholstery with a lanolin based hand cleaner or Naugahyde Cleaner. Do not use cleaners such as Lysol or Windex as they will dry out and crack the vinyl. Lanolin hand cleaner dissolves the sweat and lubricates the vinyl, maintaining its natural flexibility. Sweat is corrosive and when left on the frame and components will eventually cause corrosion or rust. When performing these cleaning sessions, it is the perfect time to inspect the equipment and note any problems for the maintenance personnel to correct.

1. Check equipment if it is operating properly.
2. Check the cable for loose fittings or frayed cable and is seating properly on the pulleys and cams.
3. Make sure that the proper weight stack selector pin is with each machine and that the pin functions properly.
4. If something appears loose be sure to have it tightened immediately.
5. If a piece of equipment appears damaged or not operation properly, place the piece out-of-service immediately.

Part Two: Maintenance

In this paragraph, we will discuss the inspection of the cables, pulleys and their associated components. If there exists the potential for injury to occur on a machine, it will most likely lie in the cable system. It is important to inspect the cables frequently and let it be known to all users that it is their responsibility to report any worn-out cable to prevent a sudden failure that can result in an injury. Cables are moving parts, meaning cable-wear will occur regardless of the type or size used. In the advent of the 3/16" mill-spec cable this wear takes longer to become apparent and this is why frequent inspections are so important.

1. Check the cable termination at the weight stack. To perform any cable tension adjustment, loosen the hex jam nut and thread the hex tap bolt in or out to give cable the proper tension. Re-tightened the hex jam nut when adjustment is complete and make sure the hex tap bolt is threaded 1/2" into the socket of the selector bar top plate.
2. Check the cable as it terminates at the cam. Check the end fitting for any signs of fraying in this area. Inspect the bolt and nut and/or screw holding the fitting and be sure that it is tight.
3. Check the cables as it passes over all pulley wheels. Visually inspect the cables and pulleys. A cable that is wearing will exhibit a ballooned surface that passes over the pulley. This is an early warning sign to replace the cable.



Maintenance

Part Three: Lubrication

Bearing and linear bearings systems have advanced over the years but they must be maintained on a regular basis if you expect them to last and perform efficiently. TuffStuff uses only the highest quality bearings and linear motion components that are virtually trouble-free but requires the regular preventive maintenance to insure long-lasting performance.

1. Bronze and nylon bushings, we recommend on a monthly basis to spray a teflon-base lubricant (silicone-free) directly onto the shaft as it passes through these bushings. Spray a small amount onto the shaft and rotate it through its complete movement and wipe off any excess.
2. Weight stack guide rods and bushings, again use teflon spray lubricant and this time spray onto a rag and wipe the guide rods down with this rag on a weekly basis. Do not use WD-40 or other lubricants as they attract dirt and will create a mess between the weight plates and bushings.
3. Sealed bearings pivot points, as the name implies are protected from the outside environment and require no lubrication. During the machine wipe down, wipe the external bearing surfaces with the damp rag and dried to prevent the build up of dust and sweat.
4. Linear bearing systems are precision, high load components that require regular maintenance. Dirt and corrosion are the major culprits in linear bearing failure. The hardened shafts must be wiped down weekly and lubricated with a light layer of teflon grease. We recommend a teflon-base (silicone-free) gel/grease for this purpose. Lack of care and maintenance will result in corrosion of the linear shaft causing the bearings to clogged and jammed.

If you religiously perform the maintenance procedures, you will increase the life of the machine and ultimately lower your maintenance costs with fewer replaced components and downtime.

Any doubts, equipment with mechanical problems should be placed "Out-of-Service" until all problems are corrected. If replacement parts are required or maintenance questions, please contact:

TuffStuff Fitness Equipment, Inc.
Service Department
1325 E. Franklin Avenue
Pomona, CA 91766
1-800-961-9377
e-mail: service@tuffstuff.net

DO NOT DISCARD THIS MANUAL



TUFFSTUFF WARRANTY

TuffStuff warrants to the original purchaser that TuffStuff equipment will be free from defects in material and workmanship. All warranty periods begin to run from the date of delivery to the original purchaser. The warranty and remedies set forth herein are conditioned upon proper storage, installation, use and maintenance and conformance with any recommendations of TuffStuff. This warranty does not cover products not manufactured by TuffStuff or products which are altered without the express written consent of TuffStuff. This warranty as specified:

FULL COMMERCIAL WARRANTY (more than 5 hours of use per day): a) Frames, welds, cams and weight plates -- Lifetime, b) Pivot bearings, pulleys, bushings, gas shocks and guide rods -- Five (5) years, c) Belts, linear bearings and pull-pin components -- One (1) year, and d) Upholstery, cables, finish and rubber grips -- Six (6) months.

LIGHT COMMERCIAL WARRANTY (less than 5 hours of use per day): a) Frames, welds, cams and weight plates -- Lifetime, b) Pivot bearings, pulleys, bushings, gas shocks and guide rods -- Five (5) years, c) Linear bearings, finish and pull-pin components -- One (1) year, and d) Upholstery, cables and rubber grips -- Three (3) months, and all other parts not mentioned elsewhere in this warranty will expire one (1) year from the date of delivery to the original purchaser. The obligation of TuffStuff under this warranty is limited to repairing or replacing warranted defective parts, as TuffStuff may elect, at TuffStuff's facility in Pomona, California, without charge to purchaser for either parts or labor. Purchaser is responsible for installation of repaired or replaced parts, and all transportation and insurance costs on returned or replaced equipment to and from TuffStuff's facility in Pomona.

THE FOREGOING SHALL CONSTITUTE THE SOLE REMEDY OF THE PURCHASER AND THE SOLE LIABILITY OF TUFFSTUFF WITH REGARD TO WARRANTY. NO IMPLIED STATUTORY WARRANTY OR IMPLIED STATUTORY WARRANTY OF MERCHANTABILITY OR FITNESS FOR A PARTICULAR PURPOSE SHALL APPLY. IN NO EVENT, WHETHER AS A RESULT OF BREACH OF CONTRACT, WARRANTY, NEGLIGENCE OR OTHERWISE, SHALL TUFFSTUFF BE LIABLE FOR SPECIAL, INCIDENTAL OR CONSEQUENTIAL DAMAGES INCLUDING, BUT NOT LIMITED TO, LOSS OF PROFITS OR REVENUE, LOSS OF USE OF EQUIPMENT, COST OF CAPITAL, COST OF SUBSTITUTION EQUIPMENT, DOWNTIME COST, OR CLAIMS OF CUSTOMERS OR PURCHASER FROM SUCH DAMAGE.

This written warranty is the final, complete and exclusive agreement of the parties with respect to the quality or performance of the equipment and no action for breach of this written warranty or any implied warranty shall be commenced more than one (1) year after the accrual of the cause of action. No modification of this warranty or waiver of its terms shall be binding on either party unless approved in writing by an authorized representative of the party. Contact TuffStuff Fitness Equipment, Inc. at 1325 E. Franklin Avenue, Pomona, California 91766, before returning any defective equipment.

TuffStuff Fitness Equipment, Inc.

1325 E. Franklin Avenue
Pomona, CA 91766, USA

Ph: 909-629-1600 Fax: 909-629-4967

E-mail: service@tuffstuff.net Net: www.tuffstuff.net