

# TUFFSTUFF<sup>®</sup>

## FITNESS



**MFT-2700** Dual-Stack Functional Trainer



ABDOMINALS



SHOULDERS



BICEPS



TRICEPS



BACK

## Compact Functionality!

The MFT-2700 redefines the standard for compact functionality!

With a main frame footprint less than sixteen square feet the MFT-2700 is the most space conscious dual stack functional trainer on the market\*. The space saving MFT-2700 delivers extreme versatility and enables the user to perform an unlimited number of functional fitness, sport specific, bodybuilding and rehabilitation exercises. The combination of Dual pivot arms that adjust to 150 different positions and custom cable routing that delivers over eight feet of independent cable travel allows hundreds of exercise possibilities. The versatile MFT-2700 allows "user defined" vertical, horizontal, diagonal and rotational resistance trajectories for safe and effective muscle isolation and confusion!

\* Represents base frame measurement. Live working area is larger. See dimensions listed on back of brochure for more details.



CHEST



LEGS

## Quality Results!

The commercially rated MFT-2700 features heavyweight construction, industrial components and dual 200 lbs. steel weight stacks, combined with modern design elements that will compliment any setting!

Magnetic selector pins and forward facing weight stacks with high visibility weight identifiers allow quick resistance changes, while hydraulically supported pivot arms and spring loaded selector handles makes adjusting the MFT-2700 simple and easy. Rotating swivel pulley brackets provide 360° of unrestricted motion and feature high strength aluminum pulleys with sealed ball bearings that are maintenance free and virtually indestructible. TuffStuff's ultra thin cables and custom ergo handles make the MFT-2700 the smoothest, most comfortable functional trainer you will ever use.

Shape your muscles, burn off body fat and say goodbye to boring exercise routines with the TuffStuff MFT-2700. TuffStuff Fitness, putting the FUN into functional fitness equipment for over forty years!

## Options & Accessories



Open frame design easily accessible for wheelchair, rehab equipment, workout benches and stability balls. Shown with optional RDM-400 Deluxe Multi-Purpose Bench.

### Available Accessories\*



Baseball  
Accessory



Baseball  
Bat Handle



Golf  
Handle



Rope  
Accessory



Multi-Use  
Handle

\* Sold individually.

## Specifications & Features

- Heavyweight 2 x 4" oval steel frame constructed of 11-gauge tubular steel with 7-gauge laser-cut adjustment plates.
- Extension arm offers 150° (15 positions) of high-to-low vertical adjustments and 165° (5 positions) of side-to-side horizontal adjustments.
- Electrostatic powder coat finish in Platinum Sparkle with Charcoal accents.
- Hydraulically supported arms for easy and safe vertical adjustments.
- Sealed ball-bearing swivel pulley bracket design.
- 4-1/2" sealed ball-bearing premium aluminum pulleys.
- Integrated exercise chart highlights basic movements and safety features.
- Two (2) 200 lbs. steel weight stacks. 1:4 ratio delivers 2.5 lbs. resistance increments and 96" of extended cable travel.
- Exercise DVD included.



Features over 40 basic body sculpting exercises.

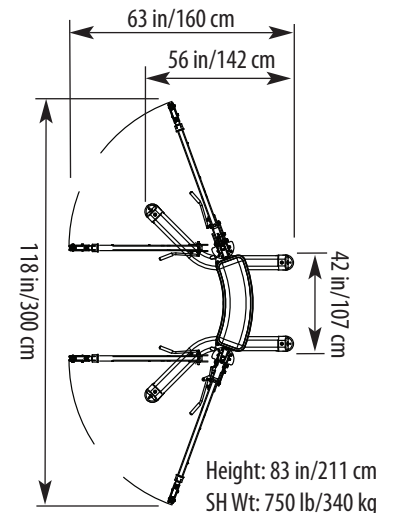

## Light Commercial Warranty

**TEN (10) YEARS:** Structural Main Frames, Welds, Cams and Weight Plates.

**FIVE (5) YEARS:** Pivot bearings, Pulleys, Bushings, Guide Rods and Gas Shocks.

**ONE (1) YEAR:** Linear Bearings and Pull-Pin Components. All other parts not mentioned elsewhere in the warranty will expire one year from the date of delivery to the original purchaser.

**SIX (6) MONTHS:** Upholstery, Cables, Finish and Rubber Grips.

**Light Commercial Use:** Light Commercial warranty applies only to facilities like hotels, apartment complexes, personal training studios, fire & police stations, etc. where the equipment would be used by no more than 30 people per day.

Refer to the Owner's Manual for details, assembly & maintenance requirements, review and understand all danger, warning and caution labels.

**Home Lifetime Warranty:** See Owner's Manual for detail.

**NOTICE:** TuffStuff continually engages in research related to product improvement. As a result, the product received by the customer may differ slightly from its published description. Improvements in materials, production techniques and design refinement may at any time be introduced into our products. TuffStuff reserves the right to make changes in its product without notice.

# TUFFSTUFF®

## FITNESS

TuffStuff Fitness Equipment Inc.

13971 Norton Avenue, Chino, CA 91710, USA PH: 909-629-1600 FX: 909-629-4967 info@tuffstuff.net

[www.tuffstufffitness.com](http://www.tuffstufffitness.com)