

# PS-234 Calf Extension

- Biomechanically correct seat angle minimizes low back strain
- Seat carriage easily adjusts to facilitate leg length
- Circular foot press bar provides smooth roll-over resistance throughout the range of motion
- 200 lbs. steel weight stack/400 lbs. resistance

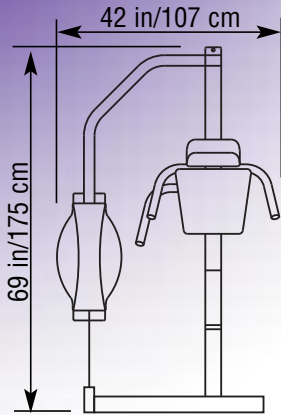

Ht: 55 in/140 cm  
SH Wt: 600 lb/272 kg



- Large aluminum diamond plate platform with dual gas assist elevation mechanism
- Multiple start positions and counter-balanced movement arm with fully adjustable roller pad to accommodate varying user heights
- Dual handrails provide balance and support
- 300 lbs. steel weight stack/150 lbs. resistance

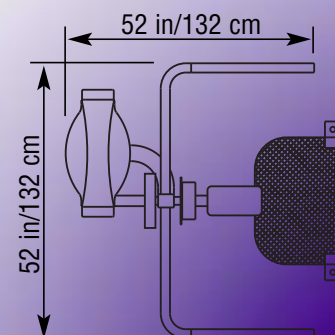

Ht: 55 in/140 cm  
SH Wt: 675 lb/306 kg

# PS-237 Multi-Hip Flexor