

ASSEMBLY INSTRUCTIONS



Revision Date 08-23-05

Apollo Modular Gym System Leg Press Station

Standard

Deluxe



America's Premier Exercise Equipment

Introduction

About the Leg Press Station

Congratulations on your new purchase of the Leg Press Station. We hope you are completely satisfied with this product and wish you many years of enjoyment.

Tuff Stuff Equipment

Every Tuffstuff product has been built to precise quality standards and has been carefully packaged to ensure that damage will not occur during shipment. The TuffStuff Warranty and signature indicating final inspection has been conducted by our line foreman, is an expression of our confidence in the completeness, the materials, and workmanship of this product.

Warranty

SEE A COPY OF WARRANTY ON BACK PAGE

Registration Card

To avoid unnecessary delays in warranty service and to insure that a permanent record of your purchase is on file with our factory, be sure to complete the warranty registration card and send it to TuffStuff Fitness Equipment today.

Specifications

1. Maximum Wt. Capacity - 200 Lbs.
2. Total Machine Weight - 150 Lbs.

Note: Due to continuing product improvements, specifications and designs are subject to change without notice.

Prior to the Assembly of the Leg Press Station

1. We advise you to consult your local Tuff Stuff retailer if you should have a question or problem regarding the proper assembly of this unit.
2. Neatly organize and identify all parts according to the Exploded View Diagram on Fold-out Pg. 7 and the Parts List on Pg. 8.

Tool Requirements

1. One 9/16" combination wrench
2. One ratchet
3. One 9/16" socket
4. One rubber mallet
5. Multi-purpose grease
6. Measuring tape
7. Utility knife

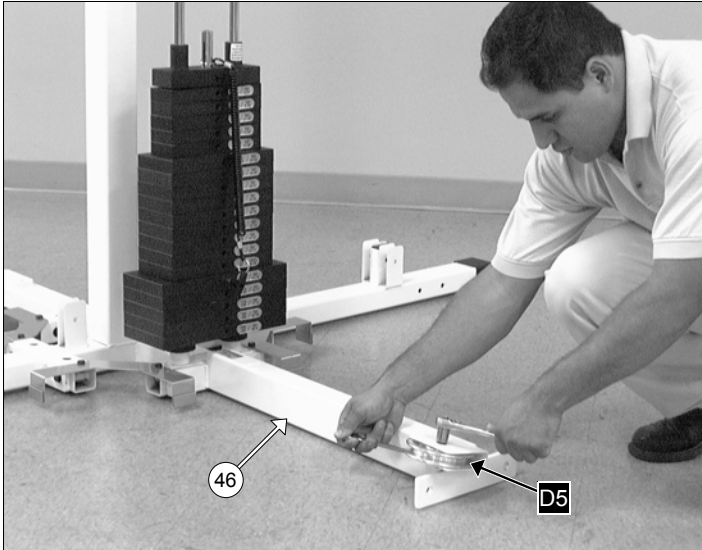
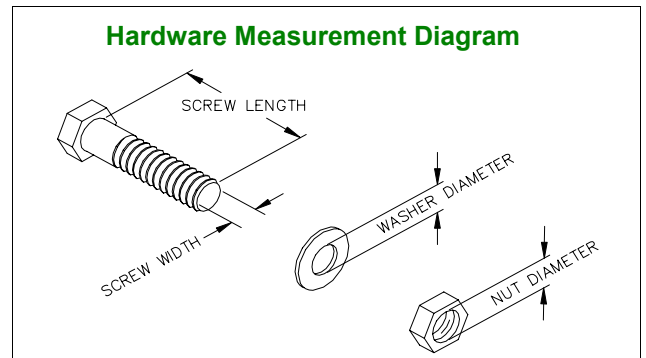

FIG. 1 Attach a Pulley 4 1/2" Rd. (#78-Labeled D5) to the **Leg Press Bottom Connector (#46)** pulley bracket using one Hex Head Cap Screw 3/8-16 X 1 3/4 (#101), two Flat Washers SAE 3/8" (#94), and one Nylon Insert Jam Lock Nut 3/8-16 (#123).

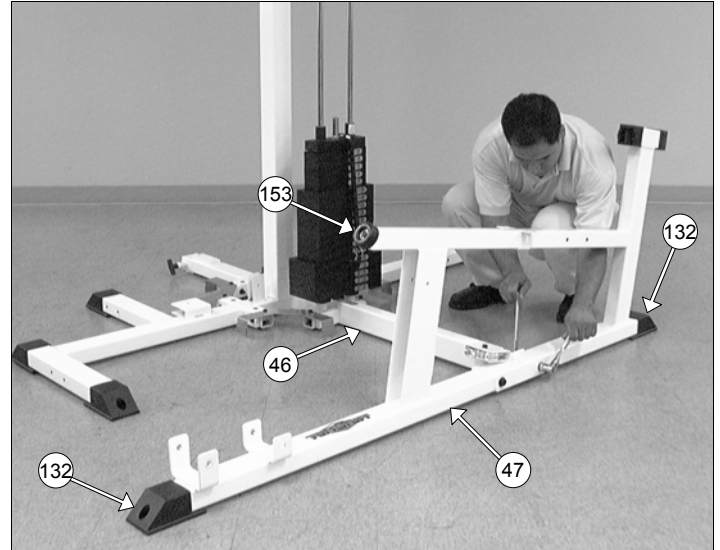

FIG. 2 Using a rubber mallet, insert two Plastic End Caps 2 X 3 (#132) onto the tube-ends of the **Leg Press Main Frame (#47)**. Next, attach the Rubber Bumper 3/8 X 2 1/2 (#153) to the tube-end of the **Leg Press Main Frame (#47)** using one Hex Head Cap Screw 3/8-16 X 1 1/2 (#100), and the Steel Bumper Washer 3/8" (#177). Next, affix the **Leg Press Main Frame (#47)** to the **Leg Press Bottom Connector (#46)** using two Hex Head Cap Screws 1/2-13 X 4 3/4 (#112), four Flat Washers SAE 1/2" (#93), and two Nylon Insert Lock Nuts 1/2-13 (#124).

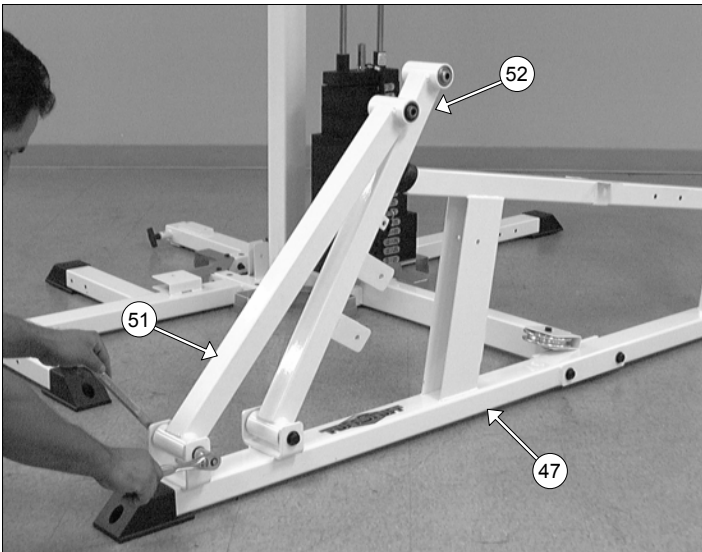

FIG. 3 Attach the **Fulcrum with Brackets (#52)** and the **Fulcrum (#51)** to the **Leg Press Main Frame (#47)** using two Hex Head Cap Screws 1/2-13 X 5 1/2 (#111), four Flat Washers SAE 1/2" (#93), and two Nylon Insert Jam Lock Nuts 1/2-13 (#127).

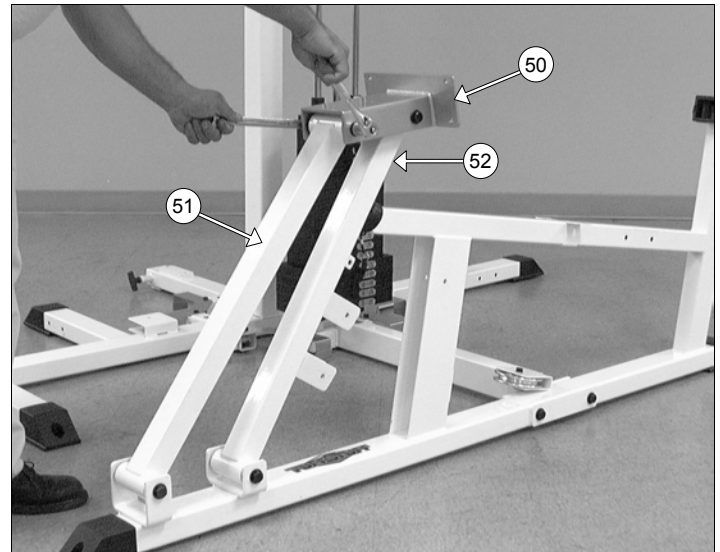

FIG. 4 Next, attach the **Foot Plate Bracket (#50)** to the **Fulcrum with Brackets (#52)** and the **Fulcrum (#51)** using two Hex Head Cap Screws 1/2-13 X 5 1/2 (#111), four Flat Washers SAE 1/2" (#93), and two Nylon Insert Jam Lock Nuts 1/2-13 (#127).

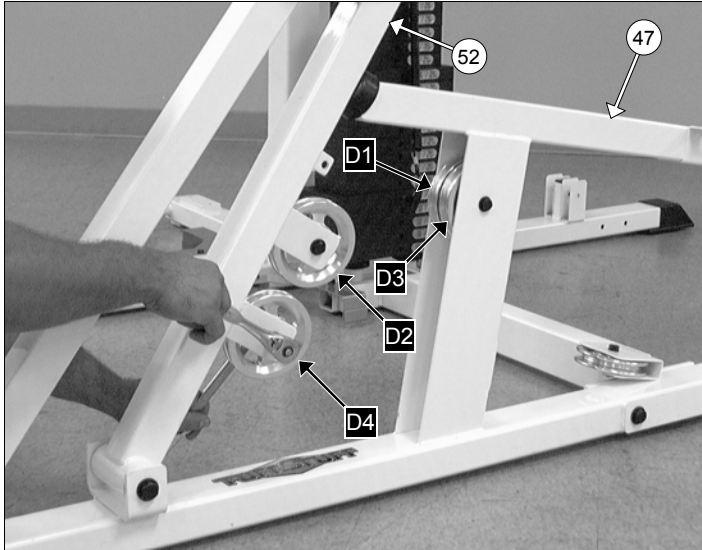

FIG. 5 Attach two Pulleys 4 1/2 Rd. (#78-Labeled D1, D3) to the **Leg Press Main Frame (#47)** using one Hex Head Cap Screw 3/8-16 X 2 3/4 (#104), two Flat Washers SAE 3/8" (#94), and one Nylon Insert Jam Lock Nut 3/8-16 (#123).

Next, attach two Pulleys 4 1/2 Rd. (#78-Labeled D2, D4) to the **Fulcrum with Brackets (#52)** using two Hex Head Cap Screws 3/8-16 X 1 3/4 (#101), four Flat Washers SAE 3/8" (#94), and two Nylon Insert Jam Lock Nuts 3/8-16 (#123).

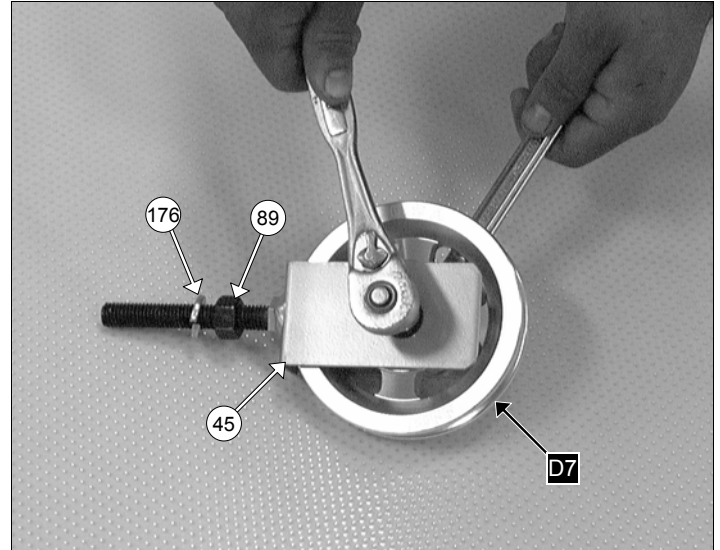

FIG. 6 Locate one of the **Adjustable Pulley Brackets (#45)** and attach one **Pulley 4 1/2 Rd. (#78-Labeled D7)** using one Hex Head Cap Screw 3/8-16 X 1 3/4 (#101), two Flat Washers SAE 3/8" (#94), and one Nylon Insert Jam Lock Nut 3/8-16 (#123). Next, thread one Finished Hex Nut 1/2-13 (#89) and insert one Split Lock Washer 1/2" (#176) onto the Screw of the **Adjustable Pulley Bracket (#45)**.

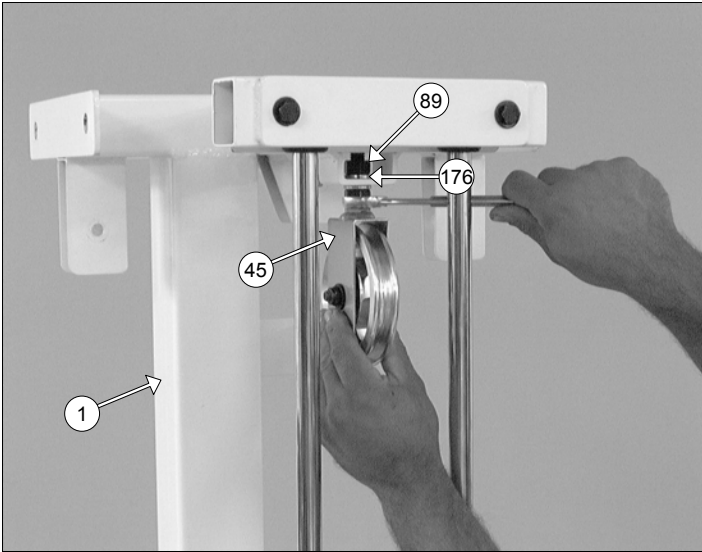

FIG. 7 Next, attach the assembled **Adjustable Pulley Bracket (#45)** to the receptacle of the **Weight Stack Frame (#1)** using one **Split Lock Washer 1/2" (#176)** and one **Finished Hex Nut 1/2-13 (#89)**.

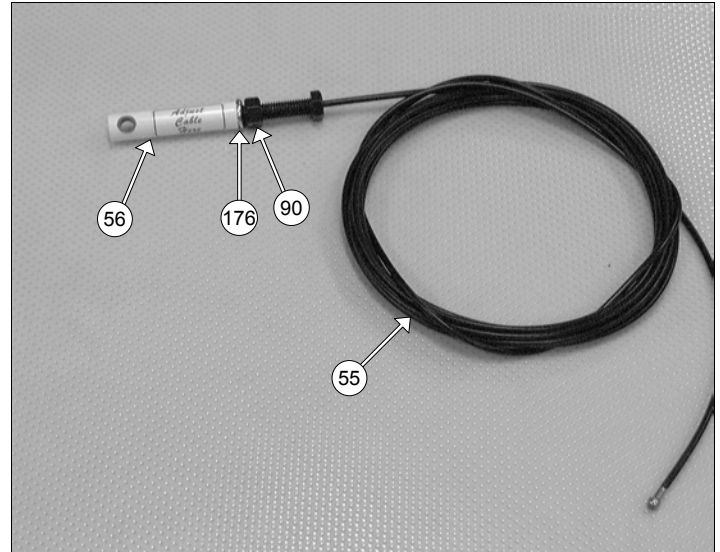

FIG. 8 Thread one **Finished Hex Jam Nut 1/2-13 (#90)** and insert one **Split Lock Washer 1/2" (#176)** onto the **Screw of the Leg Press Cable (#55)**. Next, locate the **Swivel Cable End (#56)** and thread it to the bolt of the **Leg Press Cable (#55)**.

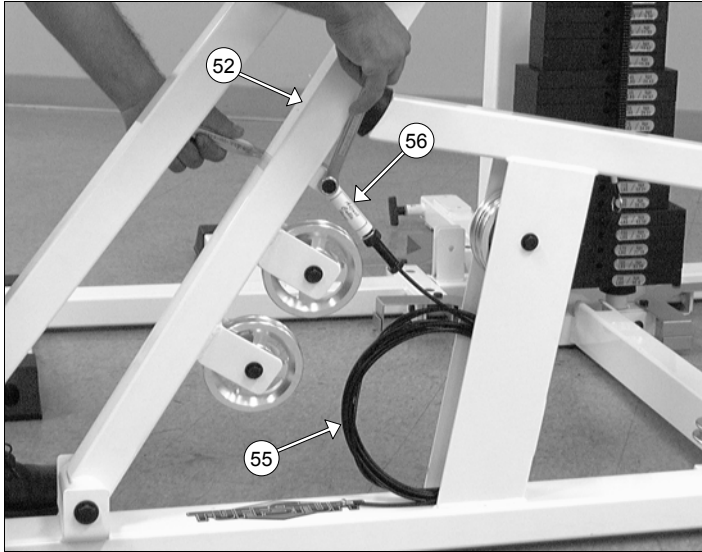

FIG. 9 Next, attach the **Swivel Cable End (#56)** to the **Fulcrum with Brackets (#52)** using one **Hex Head Cap Screw 3/8-16 X 1 3/4 (#101)**, two **Flat Washers SAE 3/8" (#94)**, one **Nylon Insert Jam Lock Nut 3/8-16 (#123)**.

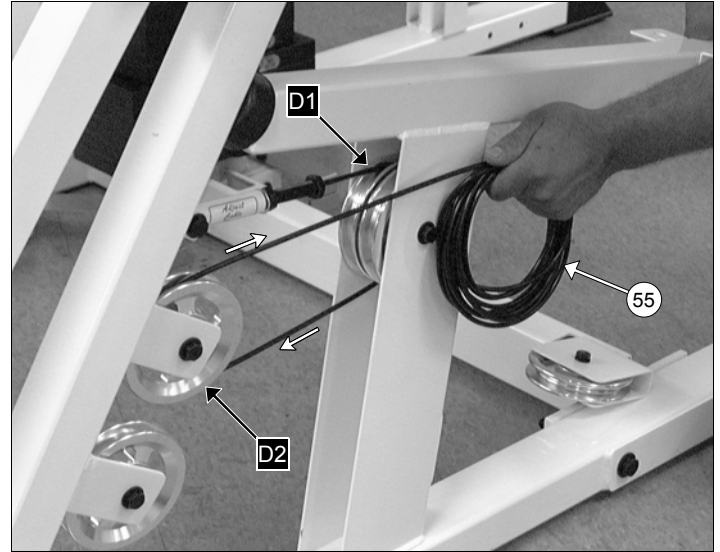



FIG. 10 Route the **Leg Press Cable (#55)** around the **Pulley 4 1/2 Rd. (#78-Labeled D1)**. Next, route under then up the **Pulley 4 1/2 Rd. (#78-Labeled D2)**.

 **Note:** Refer to the **Cable Mapping Diagram** on fold-out page 6 for further detailed illustration of the **Leg Press Cable (#55)** routing.

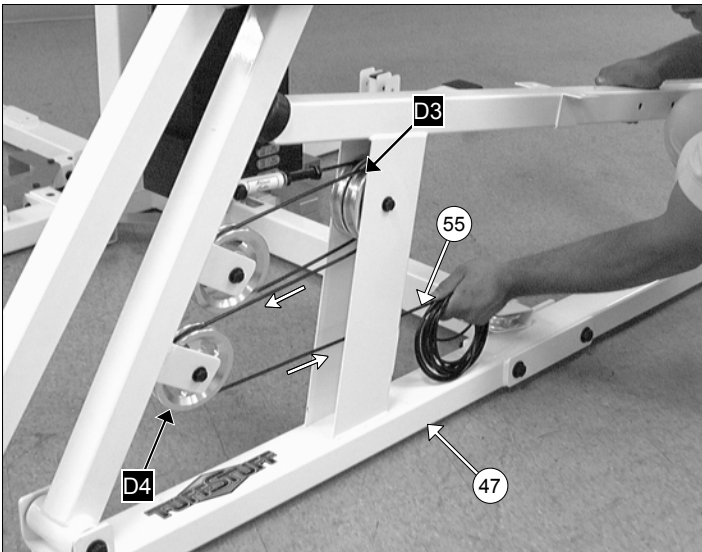



FIG. 11 Next, route the **Leg Press Cable (#55)** around the Pulley 4 1/2 Rd. (#78-Labeled D3). Next, route around the Pulley 4 1/2 Rd. (#78-Labeled D4). Continue to route through the opening of the **Leg Press Main Frame (#47)**.

 **Note:** Refer to the **Cable Mapping Diagram** on fold-out page 6 for further detailed illustration of the **Leg Press Cable (#55)** routing.

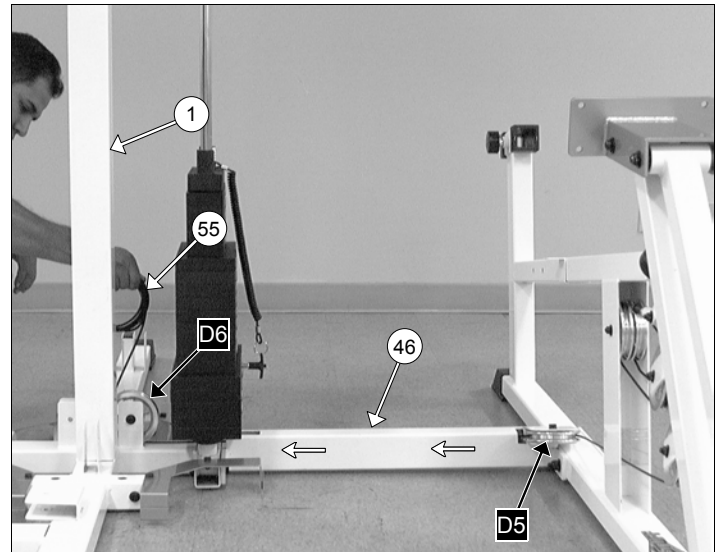



FIG. 12 Route the **Leg Press Cable (#55)** around the Pulley 4 1/2 Rd. (#78-Labeled D6). Next, route under the Pulley 4 1/2 Rd. (#78-Labeled D5).

 **Note:** Refer to the **Cable Mapping Diagram** on fold-out page 6 for further detailed illustration of the **Leg Press Cable (#55)** routing.

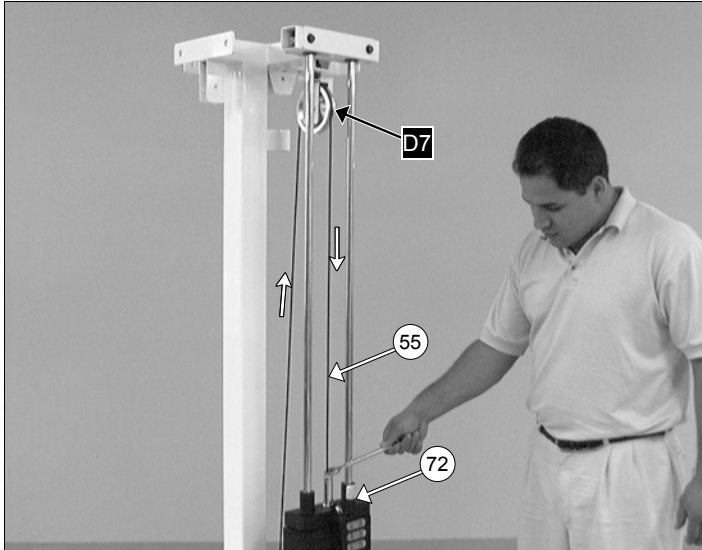



FIG. 13 Continue to route up and over the Pulley 4 1/2 Rd. (#78-Labeled D7). Next, attach the **Leg Press Cable (#55)** to the Top Plate/Selector Bar (#72) using one Split Bolt 1/2-13 X 1 (#171), and one Split Lock Washer (#176).

 **Note:** Refer to **Fig. B** on fold-out page 6 for further clarification of this hardware assembly.

 **Fully Fasten:** Proceed fully fasten this hardware assembly.

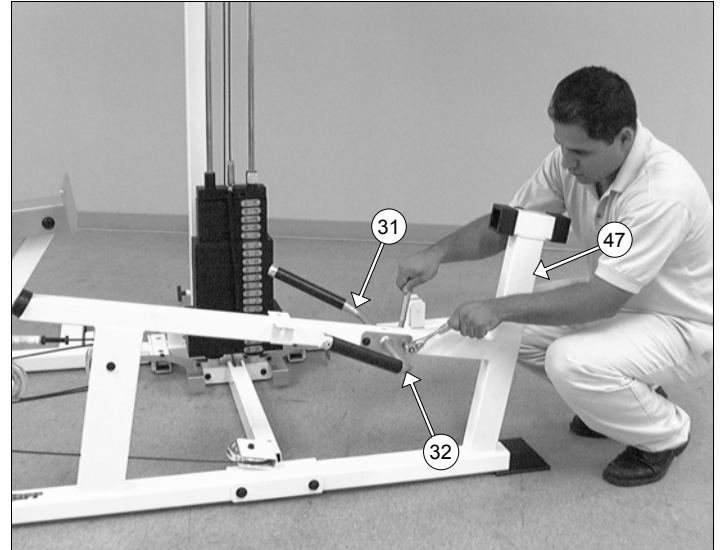

FIG. 14 Attach the **Right Handle (#31)** and the **Left Handle (#32)** to the **Leg Press Main Frame (#47)**, in the position as shown above, using two Hex Head Cap Screws 3/8-16 X 3 1/4 (#105), four Flat Washers SAE 3/8" (#94), and two Nylon Insert Lock Nuts 3/8-16 (#125).

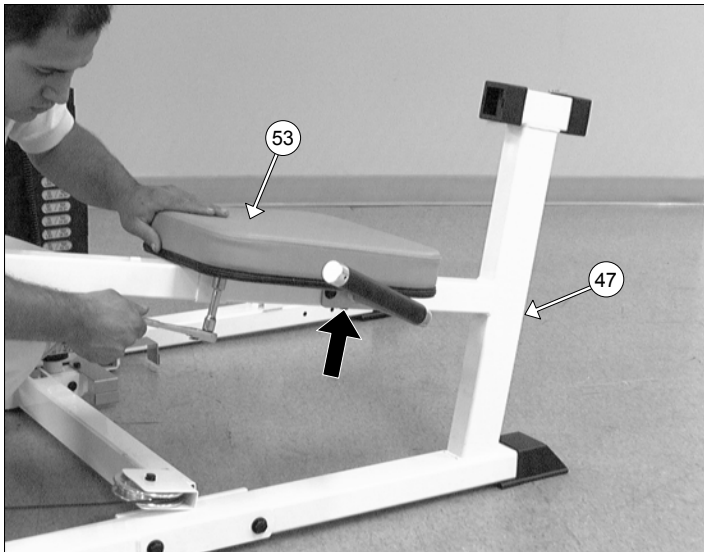

FIG. 15 Affix the **Seat Pad (#53)** to the **Leg Press Main Frame (#47)** using two Hex Head Cap Screws 3/8-16 X 1 1/4 (#99), one Hex Head Cap Screw 3/8-16 X 3 (#113-Labeled with a black arrow), and three Flat Washers SAE 3/8" (#94).



FIG. 16 Using a rubber mallet, insert one Plastic Insert Cap 1 3/4" Sq. (#140) into the tube-end of the **Adjustable Back Pad Tube (#49)**. Next, attach the **Adjustable Back Pad Tube (#49)** to the **Back Pad (#54)** using two Hex Head Cap Screws 3/8-16 X 1 1/4 (#99), and two Flat Washers SAE 3/8" (#94).

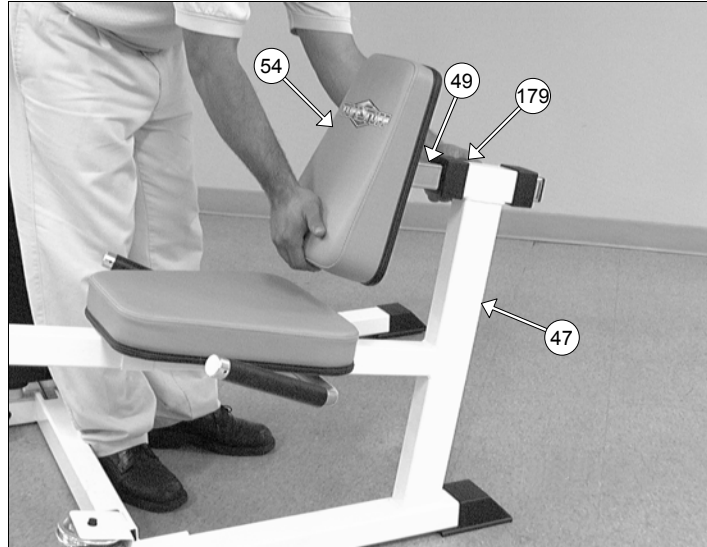



FIG. 17 Insert the assembled **Adjustable Back Pad Tube (#49)** to the **Leg Press Main Frame (#47)**.



FIG. 18  **Caution:** It is strongly recommended to use another person in assisting with this assembly.

Attach the **Foot Plate (#48)** to the **Foot Plate Bracket (#50)** using four Flat Head Socket Cap Screws 3/8-16 X 1 1/4 (#91), four Flat Washers SAE 3/8" (#94), and four Nylon Insert Lock Nuts 3/8-16 (#125).

CHART
BOLD FONT = SUB-ASSEMBLY PARTS
REGULAR FONT = HARDWARE

Leg Press Station (Deluxe) **Parts List**

ITEM NO.	DESCRIPTION	PART NO.	QTY.	ITEM NO.	DESCRIPTION	PART NO.	QTY.
31	RIGHT HANDLE	UP0270	1	100	HEX HEAD CAP SCREW 3/8-16 X 1 1/2	BNH0303	1
32	LEFT HANDLE	UP0271	1	101	HEX HEAD CAP SCREW 3/8-16 X 1 3/4	BNH0274	4
45	ADJUSTABLE PULLEY BRACKET	UP0127	1	102	HEX HEAD CAP SCREW 3/8-16 X 2	BNH0279	2
46	LEG PRESS BOTTOM CONNECTOR	UP2011	1	104	HEX HEAD CAP SCREW 3/8-16 X 2 3/4	BNH0278	1
47	LEG PRESS MAIN FRAME	UP2012	1	105	HEX HEAD CAP SCREW 3/8-16 X 3 1/4	BNH0312	4
48	FOOT PLATE	UP2014	1	111	HEX HEAD CAP SCREW GR-5 B/O 1/2-13 X 5 1/2	BNH0267	4
49	ADJUSTABLE BACK PAD TUBE	UP2015	1	112	HEX HEAD CAP SCREW GR-5 B/O 1/2-13 X 4 3/4	BNH0895	2
50	FOOT PLATE BRACKET	UP2018	1	113	HEX HEAD CAP SCREW GR-5 B/O 3/8-16 X 3	BNH0282	1
51	FULCRUM	UP2019	1	123	NYLON INSERT JAM LOCK NUT 3/8-16	BNH0365	6
52	FULCRUM WITH BRACKETS	UP2020	1	124	NYLON INSERT LOCK NUT 1/2-13	BNH0212	2
53	SEAT PAD	UP0146	1	125	NYLON INSERT LOCK NUT 3/8-16	BNH0214	8
54	BACK PAD	UP0145	1	127	NYLON INSERT JAM LOCK NUT 1/2-13	BNH0366	4
55	LEG PRESS CABLE	UP2024	1	132	PLASTIC END CAP 2 X 3	BNH0606	2
56	SWIVEL CABLE END	UP2032	1	140	PLASTIC INSERT CAP 13/4" SQ	BNH0053	1
76	ALUMINUM CAP 1" RD. (CAP-100)	BNH0537	2	144	PLASTIC TUBE GUIDE W/LIP-TEETH 2 1/4" SQ.	BNH0059	2
78	ALUMINUM PULLEY 3/8" X 4 1/2"	BNH0069	7	153	RUBBER BUMPER 3/8 X 2 1/2	BNH0511	1
80	BEARING 6203 W/TWO 1/2 BUSHINGS	BNH0835	8	156	RUBBER GRIP 1 ID X .125 X 8	BNH0966	2
82	BRONZE BUSHING 3/8 X 1/2 X 5/16	BNH0737	2	169	SOCKET SET SCREW ALLOY 10-32 X 1/8	BNH0473	4
89	FINISHED HEX NUT B/O 1/2-13	BNH0201	2	171	SPLIT BOLT Z/P 1/2-13 X 1	BNH0479	1
90	FINISHED HEX JAM NUT B/O 1/2-13	BNH0655	1	174	SPLIT LOCK WASHER 3/8"	BNH0658	1
91	FLAT HEAD SOCKET CAP SCREW B/O 3/8-16 X 1 1/4	BNH0667	4	176	SPLIT LOCK WASHER Z/P 1/2"	BNH0572	4
92	FLAT PHILLIPS MACHINE SCREW 8-32 X 1/4	BNH0408	1	177	STEEL BUMPER WASHER Z/P 3/8"	BNH0498	1
93	FLAT WASHER SAE 1/2"	BNH0238	12	179	TURN/PULL PIN W/KNOB AND LOCK	BNH0989	1
94	FLAT WASHER SAE 3/8"	BNH0239	29	180	URETHANE BUMPER 1 3/4	BNH0229	1
96	CABLE HEX TAP BOLT 1/2-13 X 3 1/2	BNH1131	1	186	DECAL-ADJUST CABLE HERE	BNH0789	1
99	HEX HEAD CAP SCREW 3/8-16 X 1 1/4	BNH0273	4	187	DECAL-EXERCISE LEG PRESS STATION	BNH1675	1

Leg Press Station (Standard) **Parts List**

All parts same as Leg Press Station (Deluxe), except for the part listed below

ITEM NO.	DESCRIPTION	PART NO.	QTY.	ITEM NO.	DESCRIPTION	PART NO.	QTY.
78	NYLON PULLEY 3/8 X 4 1/2	BNH0506	7				

DO NOT DISCARD THIS MANUAL



TUFFSTUFF WARRANTY

TuffStuff warrants to the original purchaser that TuffStuff equipment will be free from defects in material and workmanship. All warranty periods begin to run from the date of delivery to the original purchaser. The warranty and remedies set forth herein are conditioned upon proper storage, installation, use and maintenance and conformance with any recommendations of TuffStuff. This warranty does not cover products not manufactured by TuffStuff or products which are altered without the express written consent of TuffStuff. This warranty as specified:

FULL COMMERCIAL WARRANTY (more than 5 hours of use per day): a) Frames, welds, cams and weight plates -- Lifetime, b) Pivot bearings, pulleys, bushings, gas shocks and guide rods -- Five (5) years, c) Belts, linear bearings and pull-pin components -- One (1) year, and d) Upholstery, cables, finish and rubber grips -- Six (6) months.

LIGHT COMMERCIAL WARRANTY (less than 5 hours of use per day): a) Frames, welds, cams and weight plates -- Lifetime, b) Pivot bearings, pulleys, bushings, gas shocks and guide rods -- Five (5) years, c) Linear bearings, finish and pull-pin components -- One (1) year, and d) Upholstery, cables and rubber grips -- Three (3) months, and all other parts not mentioned elsewhere in this warranty will expire one (1) year from the date of delivery to the original purchaser. The obligation of TuffStuff under this warranty is limited to repairing or replacing warranted defective parts, as TuffStuff may elect, at TuffStuff's facility in Pomona, California, without charge to purchaser for either parts or labor. Purchaser is responsible for installation of repaired or replaced parts, and all transportation and insurance costs on returned or replaced equipment to and from TuffStuff's facility in Pomona.

THE FOREGOING SHALL CONSTITUTE THE SOLE REMEDY OF THE PURCHASER AND THE SOLE LIABILITY OF TUFFSTUFF WITH REGARD TO WARRANTY. NO IMPLIED STATUTORY WARRANTY OR IMPLIED STATUTORY WARRANTY OF MERCHANTABILITY OR FITNESS FOR A PARTICULAR PURPOSE SHALL APPLY. IN NO EVENT, WHETHER AS A RESULT OF BREACH OF CONTRACT, WARRANTY, NEGLIGENCE OR OTHERWISE, SHALL TUFFSTUFF BE LIABLE FOR SPECIAL, INCIDENTAL OR CONSEQUENTIAL DAMAGES INCLUDING, BUT NOT LIMITED TO, LOSS OF PROFITS OR REVENUE, LOSS OF USE OF EQUIPMENT, COST OF CAPITAL, COST OF SUBSTITUTION EQUIPMENT, DOWNTIME COST, OR CLAIMS OF CUSTOMERS OR PURCHASER FROM SUCH DAMAGE.

This written warranty is the final, complete and exclusive agreement of the parties with respect to the quality or performance of the equipment and no action for breach of this written warranty or any implied warranty shall be commenced more than one (1) year after the accrual of the cause of action. No modification of this warranty or waiver of its terms shall be binding on either party unless approved in writing by an authorized representative of the party. Contact TuffStuff Fitness Equipment, Inc. at 1325 E. Franklin Avenue, Pomona, California 91766, before returning any defective equipment.

TuffStuff Fitness Equipment, Inc.

1325 E. Franklin Avenue
Pomona, CA 91766, USA

Ph: 909-629-1600 Fax: 909-629-4967

E-mail: service@tuffstuff.net Net: www.tuffstuff.net