

# PS-203 Pec Fly

- Unique L-arms with dual pivot points allow user to maintain perfect form throughout the range of motion
- Swivel handles with rotating grips provide proper hand positioning and less wrist movement
- Dual-linkage gas assist seat adjustment
- Adjustable range of motion allows user to set starting position
- 200 lbs. steel weight stack/200 lbs. resistance

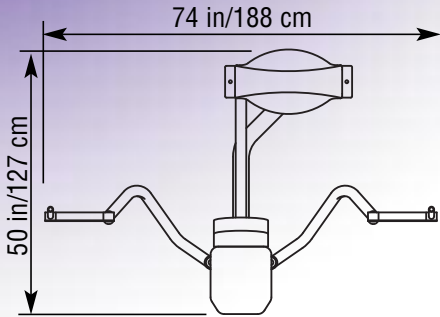

Ht: 55 in/140 cm  
SH Wt: 700 lb/318 kg



Shown with Lexan see-through protective weight shields

- Seat back angle simulates 35° incline for isolation of the desired muscle groups and reduces back strain
- Patented R.A.C. technology allows natural converging press arm movement
- Dual-linkage gas assist seat adjustment
- Pre-stretch foot lever for start and end position
- 300 lbs. steel weight stack/200 lbs. resistance

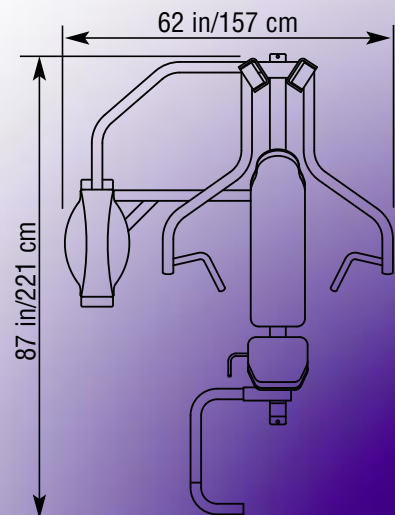

Ht: 55 in/140 cm  
SH Wt: 700 lb/318 kg

# PS-204 Incline Press